



CRYO - SERIES Ball Valve

Low Temperature and Cryogenic Ball Valves

Flo-Tite's Cryogenic Ball Valves are Specifically Designed for Cryogenic Applications.



10" TM300 Bolted Bonnet



Three Piece

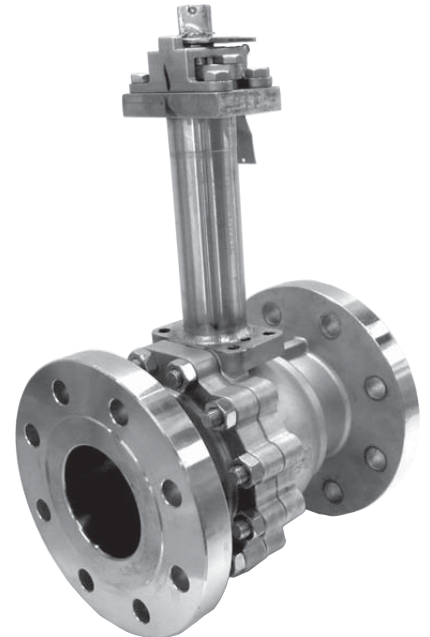

4" F300 Welded Bonnet

Cryo Series

STANDARD PRODUCT NUMBER

KEL-F (K)	Available for F150/F300 & HPF/HPS valves
CY1	Cryo Ex for 1/2" - 3/4" valves
CY2	Cryo Ex for 1" - 1 1/4" valves
CY3	Cryo Ex for 1 1/2" - 2" valves
CY4	Cryo Ex for 2 1/2" - 4" valves
CY5	Cryo Ex for 6" - 8" valves

*C/F for 10" - 12" valves

Design Features

- **Size Range:**
3PC Threaded, Socket & Butt Weld designs 1/4" thru 4"
- **ANSI 150, 300, 600 Flanged Ends** 1/2" thru 12"
- **One piece, high strength blow out proof stem design**
- **Bolt-on or welded bonnet construction**
- **Encapsulated body seals prevent "cold flow"**
- **Pressure Rating: 2000 MAWP/ WOG**
- **Components Cleaned & Degreased**
- **Uni-directional Vented Ball**
- **Live-Loaded V-Ring Packing**
- **Fire Safe Design**
- **Rigid Body Construction, Minimizes Thermal Shrinkage**
- **Fugitive Emission Compliance**
- **Trunnion Designs 2"-24" C/F**

Designed for Low Temperature and Cryogenic Applications

www.flotite.com

DIMENSIONS / TECH DATA

Our Cryo extension bonnet is specially designed to reduce heat exchange between the fluid and the environment and to keep the packing chamber temperature to a maximum. The Cryo bonnet adds dead space in which boiled off vapors collect, further insulating the top of the valve from the fluid.

Flo-Tite offers two types of extension bonnets, short and long are available to better locate the gland packing closer to the ambient temperature zone. This will protect it from freeze damage caused by low temperature fluid.

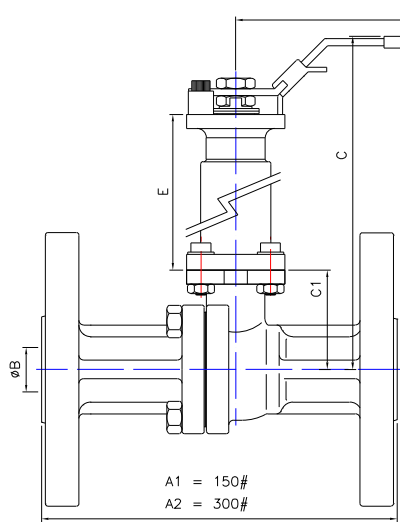

Consult factory for all trunnion design valves, & higher ANSI pressure classes.

For additional technical information such as dimensions, weights, Cv & assembly, exploded views can be found in our standard catalogues for all standard valve series.

The bonnet height can be altered to meet special requirements, consult factory for details.

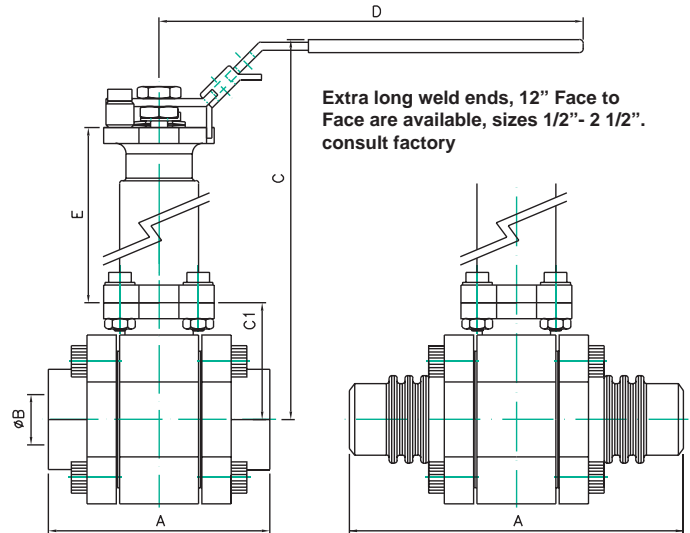

F150/F300 - ANSI Class 150/300

Size	A1	A2	B	C	C1	D	E
1/2"	4.25	5.50	0.59	11.6	1.54	6.50	9.0
3/4"	4.62	6.00	0.79	12.0	1.70	6.50	9.0
1"	5.00	6.50	0.98	12.5	2.06	7.87	9.0
1 1/4"	5.50	7.00	1.26	12.7	2.35	7.87	9.0
1 1/2"	6.50	7.50	1.50	13.2	2.65	9.84	9.0
2"	7.00	8.50	1.97	13.6	2.90	10.4	9.0
2 1/2"	7.50	9.50	2.56	18.1	3.39	15.4	11.8
3"	8.00	11.12	3.00	18.4	3.67	15.4	11.8
4"	9.00	12.0	4.00	19.1	4.40	15.4	11.8
6"	15.5	15.88	5.98	23.1	7.20	25.6	11.8
8"	18.0	19.75	7.87	23.4	7.60	37.4	11.8
10"	21.0	22.38	9.84	n/a	9.88	38.0	11.8
12"	24.0	25.5	11.8	n/a	11.5	38.0	11.8

HPF - 2000 WOG 3PC Full Bore

Size	A NPT	A BW,SW	B	C	C1	D	E
1/4"	2.72	4.81	0.46	11.7	1.54	6.50	9.0
3/8"	2.72	4.81	0.50	11.7	1.54	6.50	9.0
1/2"	2.91	4.89	0.59	11.7	1.54	6.50	9.0
3/4"	3.38	5.17	0.79	12.0	1.70	6.50	9.0
1"	3.70	5.24	0.98	12.5	2.06	7.87	9.0
1 1/4"	4.09	5.72	1.26	12.6	2.19	7.87	9.0
1 1/2"	4.61	6.19	1.57	13.3	2.65	9.84	9.0
2"	5.20	6.62	1.97	13.5	2.91	10.4	9.0
2 1/2"	7.28	8.78	2.56	18.1	3.39	15.4	11.8
3"	8.74	10.0	2.99	19.2	4.45	15.4	11.8
4"	13.5	17.0	3.94	21.3	5.53	22.5	11.8

HPS - 2000 WOG 3PC Reduced Bore

Size	A NPT	A BW,SW	B	C	C1	D	E
3/4"	3.11	4.89	0.59	11.7	1.54	6.50	9.0
1"	3.62	5.17	0.79	12.0	1.70	6.50	9.0
1 1/2"	4.13	5.72	1.26	12.6	2.19	7.87	9.0
2"	4.76	6.19	1.57	13.3	2.65	9.84	9.0
2 1/2"	5.90	8.78	1.97	13.5	2.91	10.4	9.0
3"	9.06	9.57	2.56	18.1	3.39	15.4	11.8
4"	13.5	12.01	2.99	19.2	4.45	15.4	11.8

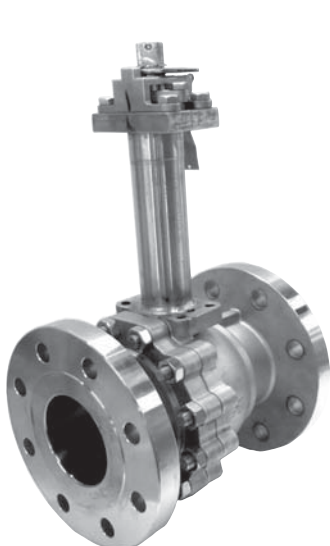

Flanged Ball Valves
Class 150/300/600

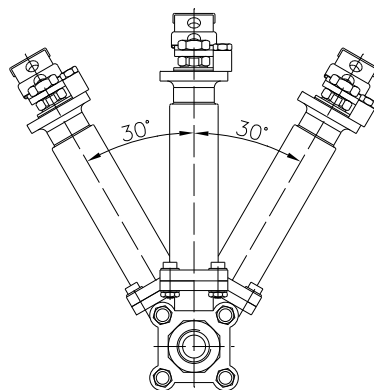

CAUTION
DO NOT install valves with extended bonnets with the extension tilted more than 30° from the upright vertical position.



Titan Series. ANSI 1500 or 3500 MAWP/WOG



Tri-Pro Series. ANSI 600 or 2000 MAWP/WOG

Selection & Technical Data

Pressure-Temperature Classification

Category	Negative Working Temperature °F	Valve Size inches	ASME Class	Extension Bonnet	Seat Material	Flow Direction
A	-22 to -60	1/2 thru 12	150/300/600	C/F	Super Tek TFM	Uni-direction
B	-61 to -250	1/2 thru 12	150/300/600	Long	Super Tek TFM or Super Tek III	Uni-direction
C	-251 to -300	1/2 thru 12	150/300/600	Long	Cryo-Tek or Kel-F	Uni-direction
D	-301 to -340	1/2 thru 12	150/300/600	Long	Cryo-Tek or Kel-F	Uni-direction

Seat Material

Seat Code	Material	Technical Description
F	Super Tek (TFM)	TFM is second generation of PTFE, traditionally has been used in cryogenic service with great success.
Y	Super Tek III	Super-Tek III is TFM blended with carbon filler, commonly known as TFM 4215, popular selection for cryogenic application.
K	Kel F (PCTFE)	Kel F has been heavily used in severe cryogenic service with reliable performance.
Q	Cryo-Tek (modified PTFE)	Cryo-Tek is a form of modified PTFE which contains bronze and other cryogenic fillers, specially suitable for LOX service.

ATTENTION
MAWP/WOG is a do not exceed pressure at normal ambient NPT & Weld End Models

Typical Cryogenic Fluids & General Applications

Category	Temperature Range (°F)	Typical Fluid
A	-22 to -94	Propane (-44°F)
B	-94 to -155	Ethane (-128°F)
C	-155 to -320	Ethylene (-155°F); Methane (-260°F); LNG (-260°F); Oxygen (-297°F); Nitrogen (-320°F)

WARNING
Threaded & Welded End Valves with MAWP/WOG Rating

The MAWP/WOG rating stands for water, oil and gas and indicates the maximum pressure per square inch that the valve can take. **Do not use WOG rated valves in services where pressure exceeds the rating.**

Pressure Build Up Prevention

The cryogenic ball valve is designed with no trapped cavities. A cavity relief hole faces upstream and eliminates pressure build up caused by thermal expansion. All balls are also provided with a 1/8" hole drilled into the stem slot of each ball to prevent excessive pressure build up in the cavity from trapped liquid when the valve is in the open position.

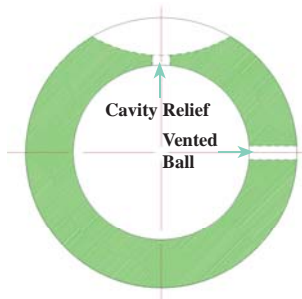

Safety

The ball has an upstream pressure relief hole to prevent over pressure from thermal expansion. The valves have an arrow showing flow direction. Cryogenic valves are unidirectional and must be installed in the correct position. All valves have name plates indicating flow direction as illustrated below.

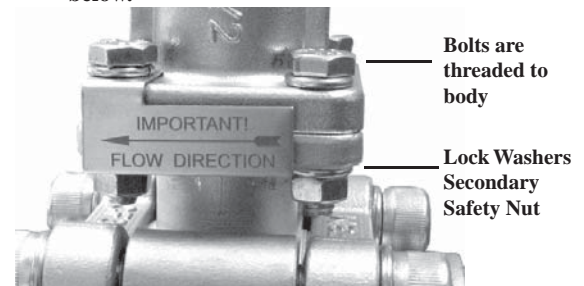

Pressure Temperature Chart

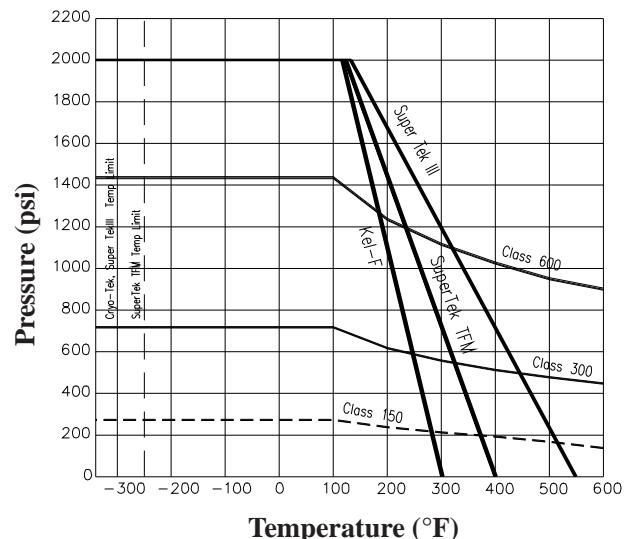

Valve Torque

Due to the nature of cryogenic fluids, valve torque can increase as a result of freezing moisture on the ball or thermal contractions of the materials. The torque curve of valves at cryogenic temperatures behaves different to those ambient temperatures as illustrated below. The torques shown include enough safety factor for actuator sizing. They are based on maximum line pressure, at lowest temperature.

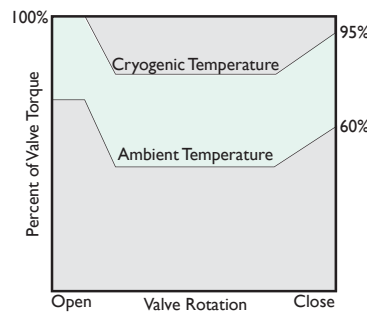

F150 / F300 - Torques

Size	TFM Seat		Kel-F Seat	
	F150	F300	F150	F300
1/2"	69	88	93	120
3/4"	99	105	135	143
1"	110	121	150	165
1 1/4"	264	308	360	420
1 1/2"	297	319	405	435
2"	396	435	540	593
2 1/2"	682	726	930	990
3"	880	990	1200	1350
4"	1870	1870	2550	2550
6"	5060	5170	6900	7050
8"	10890	11000	14850	15000
10"	18700	19580	25500	26700
12"	25300	26400	34500	36000

HPF/S 2000 WOG - Torques

Size	TFM Seat		Kel-F Seat	
	HPF	HPS	HPF	HPS
1/4"	83	n/a	113	n/a
3/8"	83	83	113	113
1/2"	94	83	128	113
3/4"	154	94	210	128
1"	209	154	285	210
1 1/4"	352	209	480	285
1 1/2"	473	352	645	480
2"	616	473	840	645
2 1/2"	1045	616	1425	840
3"	1320	1045	1800	1425
4"	2200	1320	C/F	1800

Flo-Tite's Cryo Series ball valves are designed for use in low temperature and cryogenic applications. **Low temperature service** is generally understood to mean temperatures **below freezing down to -150°F**, while the term **cryogenic** applies to service temperatures of **-150 down to -450°F**.

Cryogenic service is much more complicated and usually involves the handling of liquefied gases such as oxygen, nitrogen, hydrogen, fluorine, helium, and methane.

Serious consideration must be given to thermal expansion rates of materials since the service temperature can be more than 500°F below ambient temperature.

In liquid oxygen and liquid fluorine applications, the situation is further complicated requiring special cleaning and degreasing of all wetted parts. This is required due to the heavy risk of ignition with both these fluids if they come in contact with any hydrocarbon-based residue left on valve parts during fabrication. As a standard process, all Flo-Tite's valve components are cleaned and degreased before final assembly.

Design Features

- **Straight through flow providing minimum pressure drop and maximum flow**
- **Tight shutoff according to cryogenic standards**
- **Quick opening for automation**
- **Rugged construction with precision welding bonnet or secure bolting bonnet**
- **Blow-out proof one piece stem with enlarged diameter and wide stem-to-ball engagement, high tensile strength 17-4PH material**
- **Seats with specially designed profiles to allow flexible movement under very low temperatures**
- **Encapsulated body seals, two per side**
- **Spring-loaded body bolts to compensate for thermal contractions of valve parts during operation**
- **Live-loaded packing (Belleville washers) automatically self-adjusts for packing wear and thermal expansion.**
- **"V" type TFM stem packing with deep packing chamber to reduce stem leakage**
- **The valves are standard with ISO 5211 pad for ease of automation**

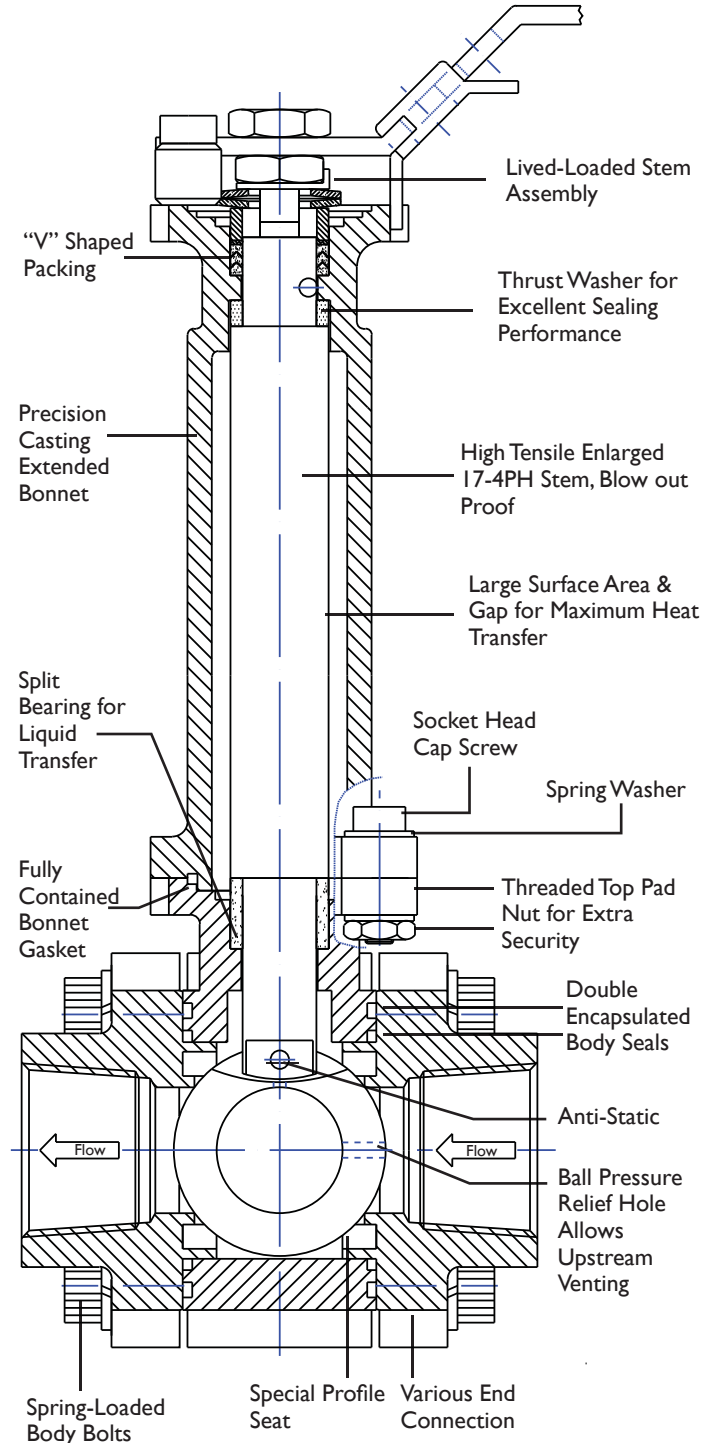

Flo-Tite, Inc.
4815 West 5th St.
Lumberton, NC 28358

P. O. Box 1293
Lumberton, NC 28359
Website: www.flotite.com

Tel: (910) 738-8904
Fax: (910) 738-9112
E-mail: flotite@flotite.com