



Three Piece Full Port Ball Valves

Flo-Tite's Unique... MULTI-CHOICE SERIES

Over 36 years of performance history

Change your End Caps to Meet All your Application Needs with Ease of Installation.

Pressure Rating:

1500 MAWP/WOG size 1/4"-2 1/2"

1250 MAWP/WOG size 3" - 4"

Size Range:

1/4" - 4"

Temperature Range:

Consult Factory



Models:

300 - (316SS)

200 - (WCB)



Cap Screw Bolting

SIZE 1/2" - 2 1/2"

Optional 6" thru 12"



I - SO - Mount

SIZE 3" & 4"

Shown with Optional Flanged Ends.

Multi -Choice Series

STANDARD PRODUCT NUMBERS

- 310-SS-1-FFF-L (SS NPT)
- 320-SS-2-FFF-L (SS SW)
- 330-SS-3-FFF-L (SS BW as an option)
- 340-SS-4-FFF-L (SS Flanged as an option)
- 210-CS-1-FFF-L (CS NPT)
- 220-CS-2-FFF-L (CS SW)
- 230-CS-3-FFF-L (CS BW as an option)
- 240-CS-4-FFF-L (CS Flanged as an option-Do not Stock)

SPECIAL FEATURES

- I-SO MOUNT TYPE AUTOMATION PAD
- WELD-IN-PLACE DESIGN
- SECONDARY MEDIA CONTAINMENT
- LIVE-LOADED STEM ASSEMBLIES
- SWING-OUT BODY DESIGN
- SAFETY LOCKING HANDLE
- ANTI-STATIC GROUNDING DEVICE
- SUPER-TEK SEATS, STANDARD
- SECONDARY METAL SEAT OPTION
- CAVITY FILLER - ALL SIZES OPTIONAL
- METAL NAME PLATES IDENTIFY ALL SOFT PARTS
- 4" STEM EXTENSION OPTION

END CAP SELECTION

- THREADED (NPT)
 - SOCKET WELD
 - BUTT WELD
 - ANSI 150/300 FLANGED CONNECTIONS
 - TRI CLAMP-SANITARY END
 - CAM LOCK
 - TUBE END
 - FLUSH BOTTOM TANK
 - EXTENDED END SW
 - EXTENDED END B/W
- V-Port Control Valve Characterized Ball V15°, V30°, V60°, V90°, specials*

UNIQUE DESIGN

- SIZE Range 1/4" thru 4" Optional 6"~12"
- 1500 WOG/150 WSP 1/4" ~ 2-1/2", 1250 WOG/150 WSP 3" - 4" ANSI 150/300 6"~12"
- CAP SCREWS are used to insure precise alignment of valve center body to end caps. This high-end design feature eliminates through bolts, nuts, washers and their related problems.

Unique 3PC Design Serves As Both Valve And Union Eliminating the Need and Cost of Two Sets of Heavy Flanges.

www.flotite.com

BILL OF MATERIALS: Size 1/4" thru 4"

| No. | Part Name | 300 Series Stainless Steel | 200 Series Carbon Steel | Qty |
|-----|-------------------------|----------------------------|-------------------------|--------|
| 1 | Body | ASTM A351 CF8M - 316 | ASTM A216 Gr. WCB | 1 |
| 2 | End Cap Connectors | ASTM A 351 CF8M @ | ASTM A216 Gr. WCB | 2 |
| 3 | Ball | ASTM A351 CF8M - 316 | ASTM A351 CF8M - 316 | 1 |
| 4 | Seats * | Super-Tek TFM or RTFE | Super-Tek TFM or RTFE | 2 |
| 5 | Body Seals * | Super-Tek TFM or RTFE | Super-Tek TFM or RTFE | 2 |
| 6 | Body Bolts | SS304 / ASTM A193 B8 | SS304 / ASTM A193 B7 | 8 / 12 |
| 7 | Stem | ASTM A276 Type 316 | ASTM A276 Type 316 | 1 |
| 8 | Anti-Static Device | SS304 | SS304 | 2 |
| 9 | Thrust Bearings * | 25% Carbon TFM | 25% Carbon TFM | 2 |
| 10 | Guide Seal * # | Viton O-Ring | Viton O-Ring | 1 |
| 11 | Stem Packings | Super-Tek TFM or RTFE | Super-Tek TFM or RTFE | 3 |
| 12 | Packing Follower | SS304 | SS304 | 1 |
| 13 | Belleville Washers | SS301 | SS301 | 2 |
| 14 | Lock Washer | SS304 | SS304 | 1 |
| 15 | Valve Stop - Set Sleeve | SS304 | SS304 | 1 |
| 16 | Valve Stop - Bolt | SS304 | SS304 | 1 |
| 17 | Thin Nuts | SS304 | SS304 | 2 |
| 18 | Lever Handle | SS304 | SS304 | 1 |
| 19 | Locking Device | SS304 | SS304 | 1 |
| 20 | Lever Sleeve | Plastic | Plastic | 1 |

* Items included in repair kits (Consult factory for B8 and B7 bolting)

@ SS Weld Ends use CF3M-316L # Check media compatibility

* Carbon Steel Bodies are Black Phosphate Coated for Added Corrosion Resistance

* All Carbon Body Valves Have Stainless Steel Hardware

SPECIFICATION STANDARDS:

- Threaded End, ANSI B1.20.1 NPT
- Socket Weld, ANSI B16.11
- Butt Weld MSS SP72
- Meets WW-V35C Type II Composition: SS Style
- Shell Wall ANSI B16.34
- Flanged End Class 150 or 300
- Valve Body and Caps are high quality investment castings
- NACE MR-01.75 compliant
- ISO 5211 Mounting Pad
- All Valves have CE Marking
- Marking Compliance to MSS SP-25

RATINGS:

- Pressure Rating:
Size 1/4" thru 2 1/2" - 1500 MAWP/WOG
Size 3" & 4" 1250 MAWP/WOG
Threaded, Socket Weld
Butt Weld schedules 5, 10, & 40
Size 6" and larger Contact Factory
- Flanged End ANSI 150/300
- Steam Rating: 150 PSI WSP
250 PSI steam rated valves are available with Super-Tek III or S-Tek(50/50) seats
- Vacuum service to 25 torr

TESTING:

All Valves Tested to MSS SP-72 at 100 psi under Water in Open and Closed Positions.

Exploded View For 1/4" ~2-1/2"

VALVE COMPONENTS

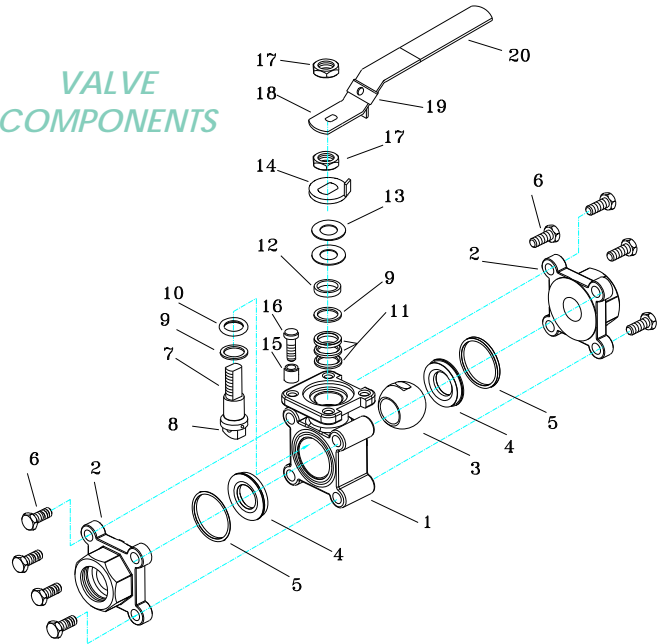

UNIQUE FEATURES

Ball Design Added Safety Feature:

As an added safety feature, there is a hole in the stem slot of each ball to equalize pressure between the body cavity and the flow stream when valve is in the open position.

Relief Holes in Seats Relieve Pressure Past the Upstream Seat.

Flo-Tite's

safety lockable handle designed to prevent accidental movement.



The valve can also be padlocked to limit unwanted access.



Flo-Tite's QUALITY CONTROL INCLUDES:

- ✓✓ All castings go through spectroscopic analysis
- ✓✓ Microstructure test after solution heat treating
- ✓✓ Inspection of appearance after shot blasting

- ✓✓ Size/dimension gauge test after CNC machining
- ✓✓ Final air pressure leakage test at 100 PSI under water in Open and Closed positions.

All 316 Stainless Steel Cast Valves Are Passivated As Standard.

DIMENSIONS, TORQUES, AND WEIGHTS:

| Size | A1 | A2 | A3 | B | C1 | C | D | Weight (lbs) | Torque (in-lbs) | Cv |
|--------|------|-------|-------|-------|------|------|-------|--------------|-----------------|------|
| 1/4" | 2.84 | 5.57 | 4.39 | 0.374 | 1.54 | 2.92 | 6.50 | 1.9 | 50 | 20 |
| 3/8" | 2.84 | 5.57 | 4.39 | 0.50 | 1.54 | 2.92 | 6.50 | 1.9 | 50 | 24 |
| 1/2" | 2.84 | 5.57 | 4.39 | 0.59 | 1.54 | 3.01 | 6.50 | 1.9 | 50 | 30 |
| 3/4" | 3.35 | 6.06 | 5.80 | 0.79 | 1.66 | 3.03 | 6.50 | 2.5 | 70 | 50 |
| 1" | 3.62 | 6.32 | 5.97 | 0.98 | 2.05 | 3.46 | 7.87 | 3.35 | 95 | 94 |
| 1-1/4" | 4.33 | c/f | - | 1.26 | 2.21 | 3.70 | 7.87 | 4.9 | 190 | 185 |
| 1-1/2" | 4.84 | 6.94 | 8.03 | 1.50 | 2.60 | 4.30 | 9.84 | 7.6 | 200 | 265 |
| 2" | 5.59 | 7.76 | 9.04 | 2.00 | 2.95 | 4.59 | 9.84 | 11.55 | 340 | 502 |
| 2-1/2" | 7.26 | c/f | - | 2.56 | 3.39 | 5.36 | 9.84 | 21.0 | 480 | 812 |
| 3" | 7.95 | 9.45 | 10.10 | 2.99 | 3.72 | 6.64 | 15.35 | 33.1 | 780 | 1148 |
| 4" | 9.06 | 10.56 | 13.90 | 4.02 | 4.35 | 7.20 | 15.35 | 54.9 | 1600 | 2130 |

NOTE: Verify the Mounting dimensions before manufacturing actuator mounting hardware.

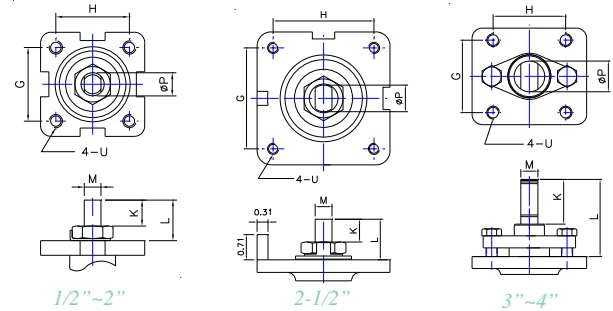
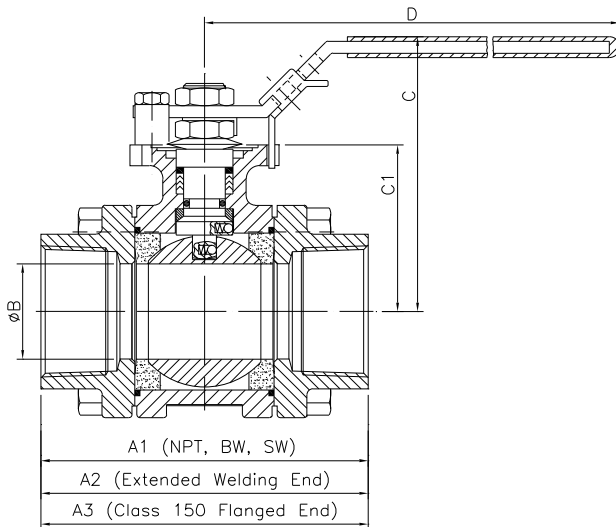

| Size | G | H | L | K | M | P | U |
|------------|-------|-------|------|------|-------|------|------------|
| 1/2", 3/4" | 1.169 | 1.169 | 0.55 | 0.32 | 0.250 | 0.38 | #10-24unc |
| 1", 1 1/4" | 1.392 | 1.392 | 0.75 | 0.43 | 0.315 | 0.44 | 1/4-20unc |
| 1 1/2", 2" | 1.949 | 1.949 | 0.91 | 0.55 | 0.374 | 0.63 | 5/16-18unc |
| 2-1/2" | 2.840 | 2.840 | 1.14 | 0.69 | 0.472 | 0.75 | 5/16-18unc |
| 3", 4" | 2.840 | 2.840 | 3.07 | 1.75 | 0.669 | 1.10 | 1/2-13unc |

DESIGN & TECHNICAL DATA

Model Numbers:

End Connections:

| STAINLESS | CARBON | CONNECTIONS |
|-----------|--------|-------------------------|
| 310 | 210 | THREADED END |
| 320 | 220 | SOCKET WELD |
| 330 | 230 | BUTT WELD |
| 340 | 240 | 150 LB. FLANGE |
| 350 | -- | TRI CLAMP -SANITARY END |
| 360 | 260 | CAM LOCK |
| 370 | -- | TUBE END |
| 395 | 295 | EXTENDED END B/W |
| 390 | 290 | GROOVED END |
| TK300 | TK200 | FLUSH BOTTOM TANK |

Any combination of above end connections are available C/F.

Consult Ball Valve Identification Code Guide for Full Part Number, Tech Bulletin page 188

OPTIONAL SEAT MATERIALS

- UHMWP-Ultra High Molecular Weight Polyethylene
- Carbon-Filled Teflon
- Bronze-Filled Teflon
- Stainless Teflon
- Virgin Teflon
- Peek
- Super-Tek (TFM)
- Super-Tek III (Carbon/TFM)
- Cavity Fillers

PRESSURE & TEMPERATURE DATA

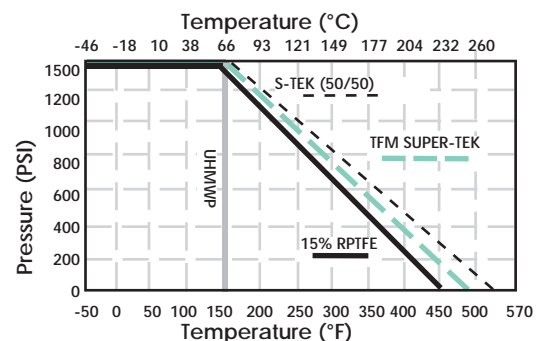

ATTENTION
MAWP/WOG is a do-not exceed pressure at normal ambient Npt & Weld End Models

Flo-Tite's Van Guard stem sealing system is designed to minimize fugitive emissions, increase safety and provide an immediate ball valve solution to the newer EPA performance requirements for valves having a leak rate of 500ppm.

Flo-Tite's Van Guard seal is a state of the art stem sealing system, which incorporates a triple set of valve stem seals. This unique system eliminates the possibility of valve stem leaks in most media applications.

STAGE I - FRONT LINE

Stage I provides a front line defense against leakage. The blow-out proof stem shoulder has a 45 degree bell shaped slope. The bell shaped design offers more sealing surface, effectively blocking all leak paths during rotation. The wedging action of the portion of the stem is far superior to the common, small flat-stem shoulder designs.

STAGE II - GUIDE-SEAL

The O-ring originated early in valve design and has been a proven performer in high cycle applications. Its basic function reduces the potential of machining imperfections and provide a low torque flexible seal. This center guide also helps to maintain a perfect stem alignment, by eliminating side loading stress which can cause stem leaks.

Standard offered with Viton material. Consult factory if other material is required.

STAGE III - LIVE-SEAL

Live-Seal is considered the intellectual component and the workhorse of Flo-Tite's Van Guard stem sealing system. Working in unison with stages I and II, stage III calls upon the use of V-Ring packing sets which expands sideways as it is compressed and pressurized blocking all air pockets. The Van-Guard stem system is energized by Belleville washers, which continuously adjusts packing compression to compensate for wear, pressure, or temperature fluctuations.

Whether your service involves volatile organic compounds, volatile hazardous chemicals, or air pollutants, Flo-Tite's ball valves are dependable, long lasting, and fully maintainable. Flo-Tite has various valve solutions and designs that provide end users freedom of choice for the toughest requirements imposed by the industry and by international standards.

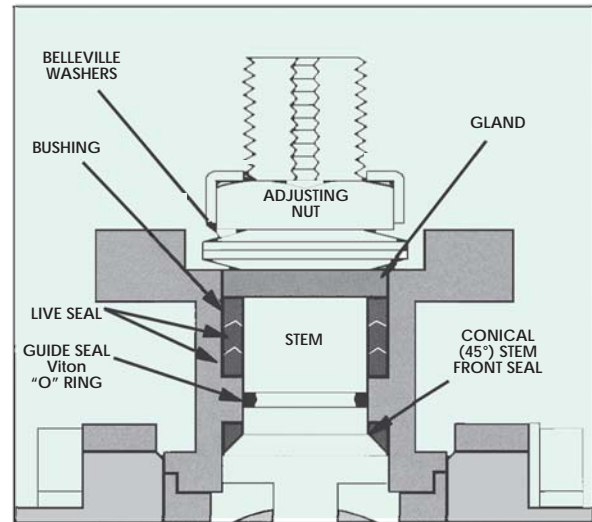

ADVANTAGES OF CAP SCREW BOLTING



Solid construction with double the number of body bolts threaded to more than half their length, results in a reduction in linear thermal expansion of the bolts and a dramatic decrease in the likelihood of leakage from the body. In addition, spring washers can be used to compensate for thermal contractions of valve parts during severe operation.

MATERIAL IDENTIFICATION



Flo-Tite's marking system follows MSS SP-25-1998 guidelines. In addition to the cast body information, we have decided to add metal nameplates that identify all valve soft parts. Valve users worldwide will be able to contact Flo-Tite quickly for any installation or service requirements as the company website address will be on all valves.

WELD-IN-PLACE

Super-Tek high temperature seat capabilities allow weld end ball valves to be welded to the piping system without disassembly, following special welding procedures. This unique advantage results in ease of installation and cost savings while insuring full integrity of the factory assembled and tested valve.



Model # 335/325
Extended Ends



Flo-Tite, Inc.
4815 West 5th St.
Lumberton, NC 28358

P. O. Box 1293
Lumberton, NC 28359
Website: www.flotite.com

Tel: (910) 738-8904
Fax: (910) 738-9112
E-mail: flotite@flotite.com